

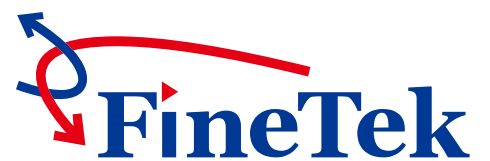

## EPR Paddle Wheel Flow Meter



[www.fine-tek.com](http://www.fine-tek.com)



# FineTek Flow Lab



FineTek is the company who owns a Second Class flow test laboratory in Taiwan. With the most professional R&D team, FineTek develops various high precision flow meters and related parts. Moreover, FineTek is certificated and constantly validated by First Class accreditation organization, the Flow Laboratory of the National Measurement Laboratory, R.O.C (Center for Measurement Standards, ITRI), which is approved to guarantee the accuracy on the flow measurement in each delivery. The TAF flow laboratory of FineTek has been certificated and approved by Taiwan Accreditation Foundation (TAF) and conforms to the regulations of international organizations such as ILAC and APALC. It has the complete ability to conduct uncertainty testing and rating for flow test.

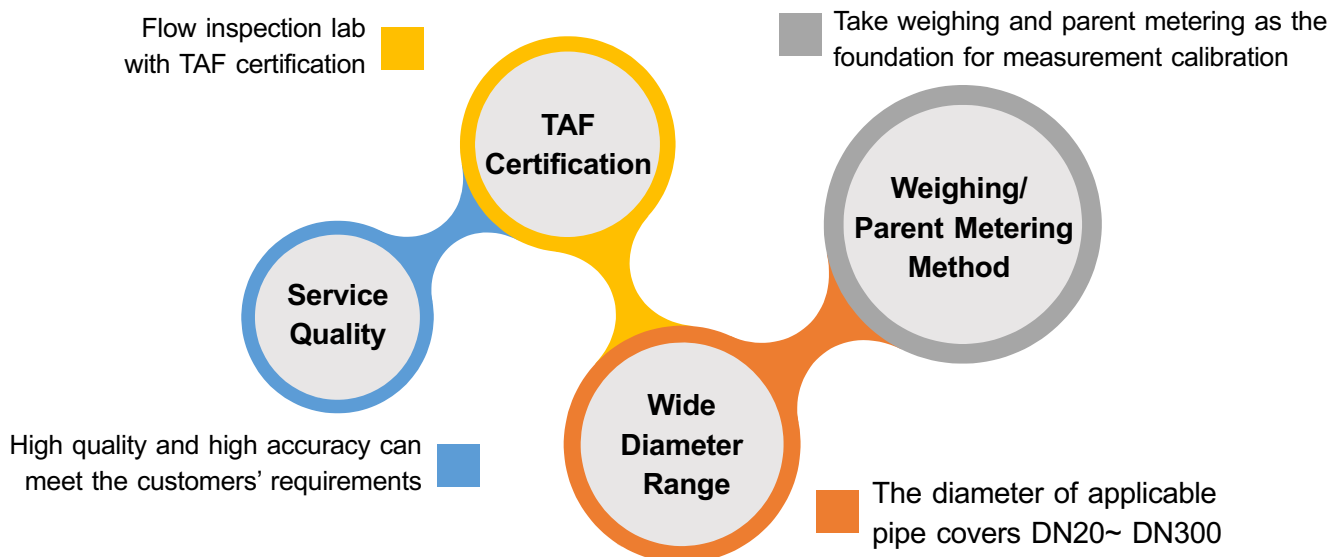

# EPR PADDLE WHEEL FLOW METER

---

---

---

---

---

---

## WORKING PRINCIPLE

The Paddle Wheel Flow Meter measures the flow velocity by using the fluidic to drive the blade rotation, and calculates the flow rate based on the flow velocity. ERP1 series flow meter consists of flow transmitter and pipe fitting. The light and compact design allows the user to carry, install and operate it conveniently. The product is calibrated by professional flow test device, with the accuracy of K value reaching  $\pm 3\%$ . The measuring range is 0.3 ~10m/s, with high linearity. Display and non-display type are both available. The display type is built-in with accumulated flow storage device.

## FEATURES

- Controlled by a microprocessor, with convenient operation and comprehensive functions.
- Power supply: 12-36 Vdc.
- Analog output: 4-20mA with 10% higher range as 4-21.6mA
- Simulated test output: 0-24 mA.
- Pulse output: Optical-coupling transistor output.
- Simulated frequency output: 0-300Hz
- Pure sensing non-display type is for convenient system integration
- LCM (Graphic 128x64 Dots) display type
- Built-in FRAM (Ferroelectric Random Access Memory) flash memory
- Easily separated from the sensor.
- LED indicator displays the alarm status.
- Upper limit settings of the analog output.
- Analog output flow rate and velocity filter settings: 0-40 segments.
- LED shows three back-lit modes, ON/OFF/In Operation.
- With RS485 communication.
- Parameter settings (K factor, pipe diameter, device ID, baudrate).
- Supports Traditional Chinese, Simplified Chinese, English, etc.

## APPLICATIONS

The Paddle Wheel Flow Meter is applicable to neutral or corrosive liquids that are non-granular or non-viscous. It connects with an analog output and pulse output signal to form a monitoring system, which can display instantaneous flow and accumulated flow. Moreover, it can form a control circuit to adjust the valve or operate the switch.

- Food industry
- Beverage industry
- Water treatment industry
- Pharmaceutical industry
- Dyeing industry
- Chemical industry
- Semi-conductor industry
- PCB wet process control

# STANDARD SPECIFICATIONS

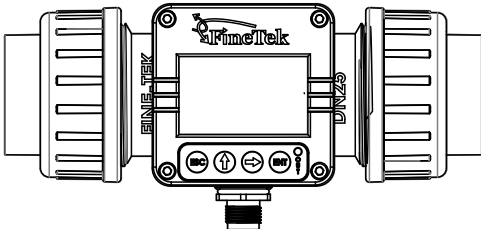
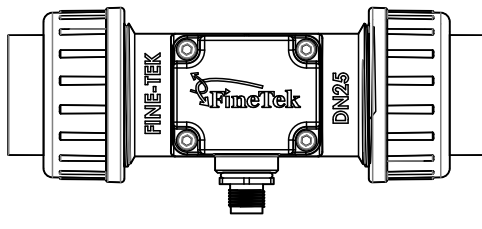
Model Type				
SPEC	<b>EPR13</b> Intelligent All-in-one model	<b>EPR12</b> Flow transmitter model	<b>EPR10</b> Pulse output model	
Applicable pipe diameter	DN20、DN25、DN40、DN50			
Flow velocity range	0.3~10m/s			
Accuracy	Under standard K Factor $\pm 3\%$ (Flow velocity 6~10m/s reach $\pm 0.5\%$ )			
Linearity	$\pm 0.5\%$ F.S.(10m/s)			
Repeatability	$\pm 0.4\%$			
Measuring principle	Magnetic			
Viscosity range	300 cSt , max.			
Impurity range	1% , max.(Size of particles 0.5mm max.)			
Process temp.	Engineering plastics: $-15^{\circ}\text{C}\sim 60^{\circ}\text{C}$ ( $5^{\circ}\text{F}\sim 140^{\circ}\text{F}$ ) Stainless steel: $-15^{\circ}\text{C}\sim 100^{\circ}\text{C}$ ( $5^{\circ}\text{F}\sim 212^{\circ}\text{F}$ )			
Ambient humidity	< 80%, non-condensing			
Installation method	Transmitter +T-fitting			
Process pressure	10-bar , max.			
IP rating	IP66, the connector shall be inserted and fastened			
Analog output	4~20mA		N/A	
impedance	1300 $\Omega$ at 36Vdc, 1000 $\Omega$ at 30Vdc, 700 $\Omega$ at 24Vdc 450 $\Omega$ at 18Vdc, 200 $\Omega$ at 12Vdc			
Pulse output	NPN , PNP 200mA overcurrent protection		N/A	
Frequency range	0~300Hz		N/A	
Display	LCM,128*64		N/A	
Back-lit	YES		N/A	
Power supply voltage	12~36Vdc , $\pm 10\%$			
Power consumption	< 1.5VA			
Reverse protection of power supply	YES		YES	
Communication port	RS485,Modbus		N/A	
Accumulated flow storage device	16K,FRAM		NO	

# DIMENSIONS

## INTELLIGENT ALL-IN-ONE MODEL

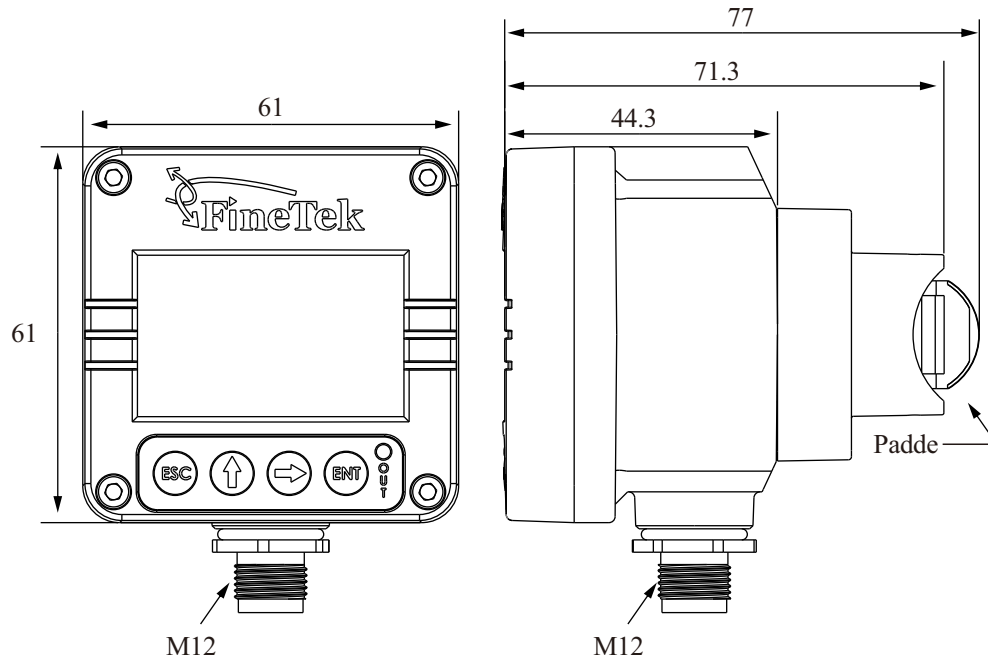

## FLOW TRANSMITTER MODEL & PULSE OUTPUT MODEL

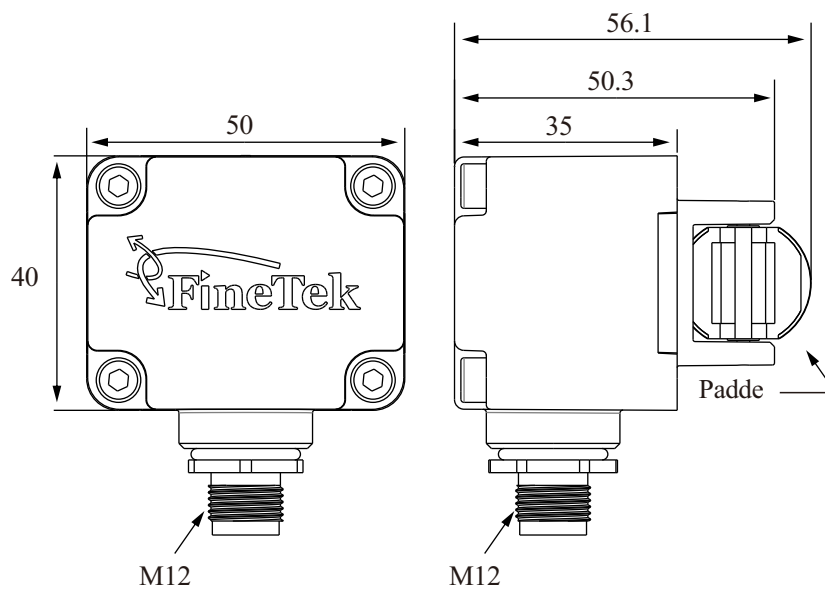

# DIMENSIONS

## INTELLIGENT ALL-IN-ONE MODEL (ENGINEERING PLASTICS)

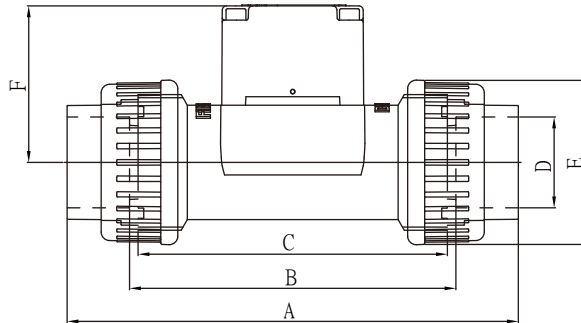

Diameter- DN (mm)	Pipe standards	A (mm)	B (mm)	C (mm)	D (mm)	E (mm)	F (mm)
20	DIN/ISO ASTM JIS CNS 4053-1	144	106	100	25 26.7 26.45 26	53	76.3
25	DIN/ISO ASTM JIS	159	115	109	32 33.4 32.55	58	76.7
40	DIN/ISO ASTM JIS	189	125	119	50 48.3 48.7	83	83.3
50	DIN/ISO ASTM JIS CNS 4053-1	216	140	130	63 60.3 60.8 60	103	90

## INTELLIGENT ALL-IN-ONE MODEL (STAINLESS STEEL)

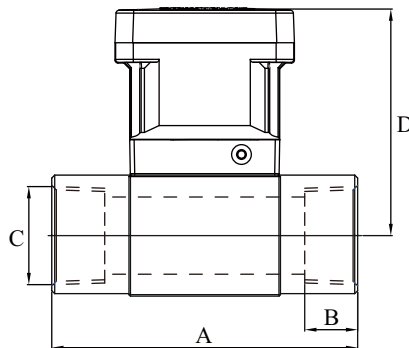

Diameter- DN (mm)	A (mm)	B (mm)	C (mm)	D (mm)
25	104	23 18 18	PF 1" PT 1" NPT 1"	77
40	129	23 22 22	PF 1-1/2" PT 1-1/2" NPT 1-1/2"	83.4

# DIMENSIONS

## FLOW TRANSMITTER MODEL & PULSE OUTPUT MODEL (ENGINEERING PLASTICS)

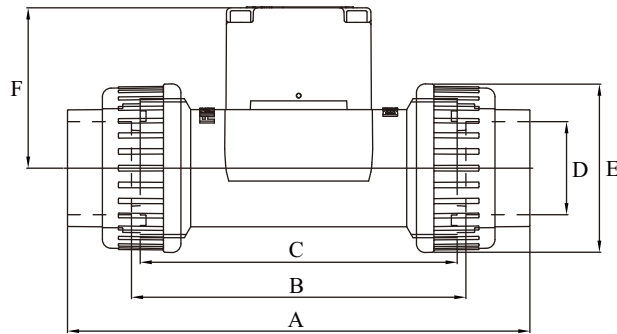

Diameter- DN (mm)	Pipe standards	A (mm)	B (mm)	C (mm)	D (mm)	E (mm)	F (mm)
20	DIN/ISO ASTM JIS CNS 4053-1	144	106	100	25 26.7 26.45 26	53	54.8
25	DIN/ISO ASTM JIS	159	115	109	32 33.4 32.55	58	55.2
40	DIN/ISO ASTM JIS	189	125	119	50 48.3 48.7	83	62
50	DIN/ISO ASTM JIS CNS 4053-1	216	140	130	63 60.3 60.8 60	103	68.5

## FLOW TRANSMITTER MODEL & PULSE OUTPUT MODEL (STAINLESS STEEL)

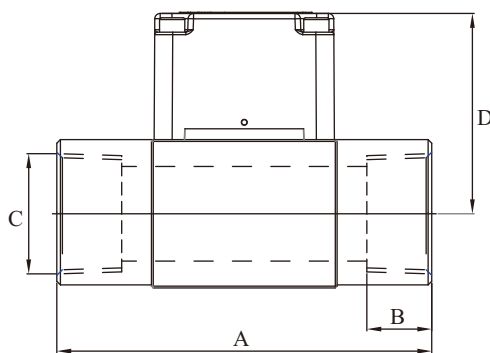

Diameter- DN (mm)	A (mm)	B (mm)	C (mm)	D (mm)
25	104	23 18 18	PF 1" PT 1" NPT 1"	55.6
40	129	23 22 22	PF 1-1/2" PT 1-1/2" NPT 1-1/2"	62

# DIMENSIONS

## T-FITTING(ENGINEERING PLASTICS)

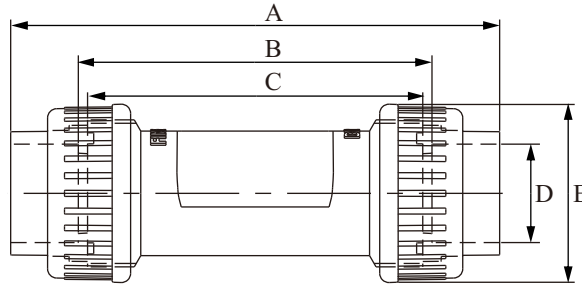

Diameter- DN (mm)	Pipe standards	A (mm)	B (mm)	C (mm)	D (mm)	E (mm)
20	DIN/ISO ASTM JIS CNS 4053-1	144	106	100	25 26.7 26.45 26	53
25	DIN/ISO ASTM JIS	159	115	109	32 33.4 32.55	58
40	DIN/ISO ASTM JIS	189	125	119	50 48.3 48.7	83
50	DIN/ISO ASTM JIS CNS 4053-1	216	140	130	63 60.3 60.8 60	103

## T-FITTING (STAINLESS STEEL)

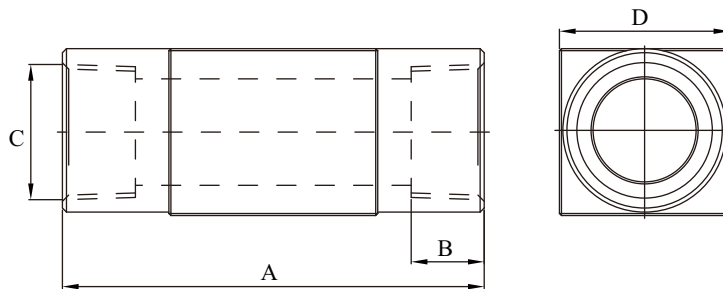

Diameter- DN (mm)	A (mm)	B (mm)	C (mm)	D (mm)
25	104	23 18 18	PF 1" PT 1" NPT 1"	55.6
40	129	23 22 22	PF 1-1/2" PT 1-1/2" NPT 1-1/2"	62

## SELECTING FLOW AND PIPE DIAMETER

Pipe diameter (mm)	Flow Range (m <sup>3</sup> /h)	
	Flow velocity 0.3m/s (min)	Flow velocity 10m/s (max)
20	0.34	11.31
25	0.53	17.67
40	1.35	45.23
50	2.12	70.68

## RELATIONSHIP BETWEEN K VALUE AND FITTING DIAMETER

Material	Connection & Standard Type	K Factor (Pulse/Liter)			
		DN20	DN25	DN40	DN50
Intelligent All-in-One Model					
PVC	DIN/ISO	70	49	17	9.2
	ASTM	70	49	17	9.2
	JIS	70	49	17	9.2
	CNS 4053-1	70	---	---	---
Stainless	Thread PF	---	49	17	---
	Thread PT	---	49	17	---
	Thread NPT	---	49	17	---
Flow transmitter type & Pulse Output type					
PVC	DIN/ISO	56.5	30	8.3	5.92
	ASTM	56.5	30	8.3	5.92
	JIS	56.5	30	8.3	5.92
	CNS 4053-1	56.5	---	---	5.92
Stainless	Thread PF	---	30	8.3	---
	Thread PT	---	30	8.3	---
	Thread NPT	---	30	8.3	---

\*US: GL (Gallon)K factor = Pulse/Liter x 3785; UK: GL (Gallon) K factor = Pulse/Liter x 4546.

## CONTROL SYSTEM DIAGRAM

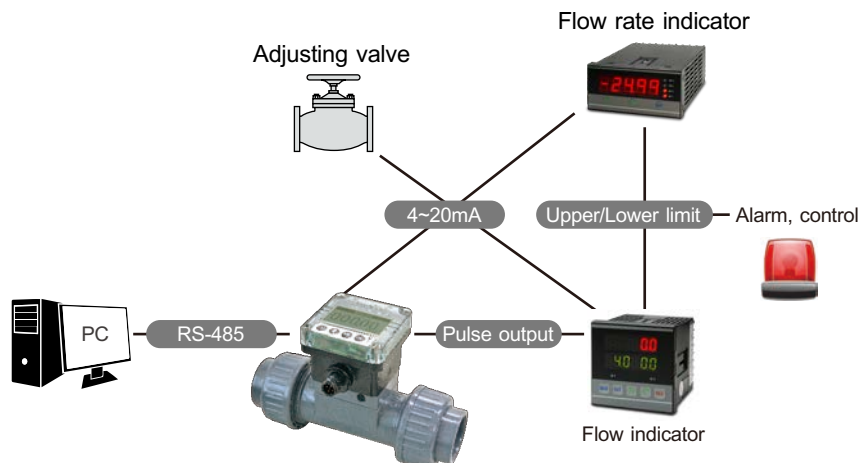

# TRANSMITTER INSTALLATION

## DISPLAY TYPE

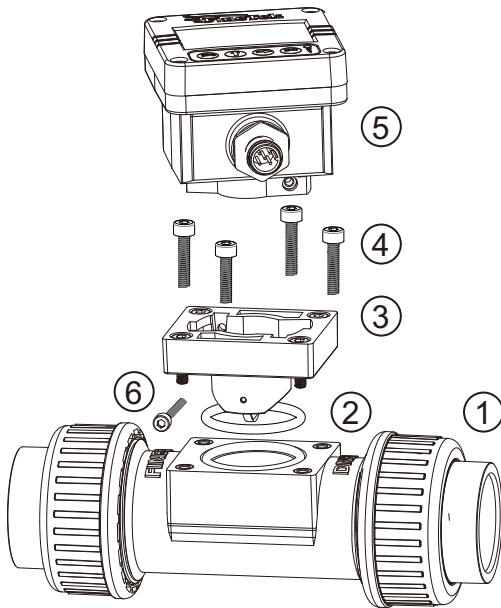

### Installation steps

1. T-fitting of flow meter.
2. Place the O-shaped ring in the sealing tank, and unfold it naturally.
3. Make the blade holder face downward and go through the hole and O-shaped ring. Level and align it.
4. Fasten and align the 4 screws evenly with the fastening torque =8~10kgf-cm(0.784~0.98N.m)
5. Point the M12 connector of the display towards you, and insert it into the slot. Level it horizontally and rotate it clockwise to the edge for alignment.
6. Fasten the 2 fixing screws.

\*Fastening torque=6~8kgf-cm(0.588~0.784N.m)

\*Note: The above steps are for whole machine installation. To install the header only, please perform steps 5~6. Please apply the fastening torque on the screws as required.

## NON-DISPLAY TYPE

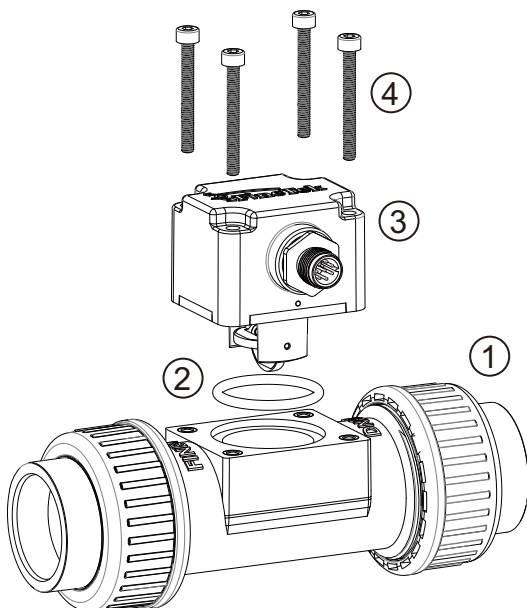

### Installation steps

1. T-fitting of flow meter.
2. Place the O-shaped ring in the sealing tank, and unfold it naturally.
3. Make the blade of the transmitter face downward and go through the hole and O-shaped ring. Level and align it.
4. Fasten and align the 4 screws evenly.

\*Fastening torque= 8~10kgf-cm(0.784~0.98N.m)

\*Note: Please apply the fastening torque on the screws as required.

## M12 CONNECTOR

Connector socket

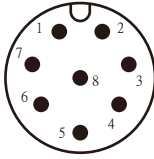

Plug

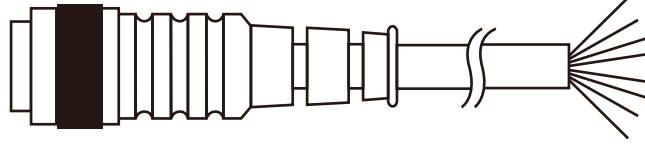

Cable

M12 Socket Pin No.	Function	Cable Color
1	Communication output RS485 -	Black
2	Pulse output Pulse -	Yellow
3	Power supply input DC 0V -	Blue
4	Pulse output Pulse +	Pink
5	Communication output RS485 +	Green
6	Analog output 4~20mA -	Purple
7	Analog output 4~20mA +	Red
8	Power supply input DC12~36V +	Brown

## WIRING

4~20mA output

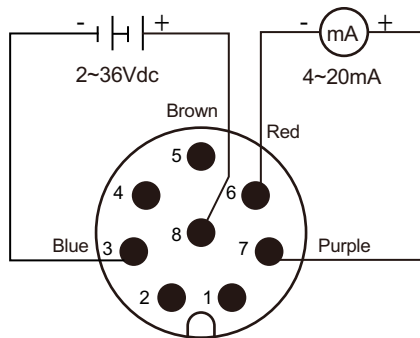

Communication output RS-485

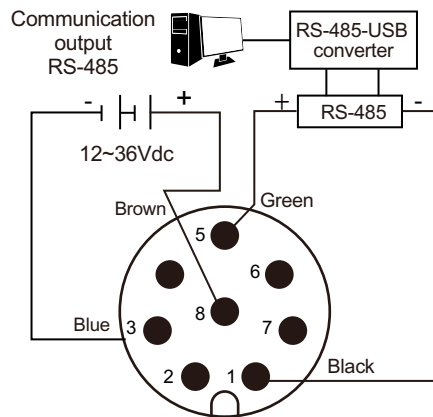

Pulse output NPN

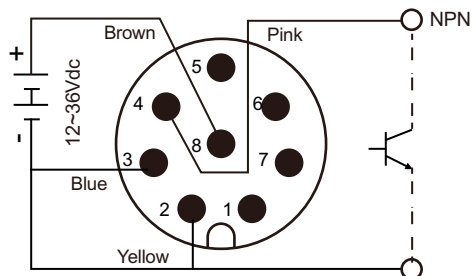

Pulse output PNP

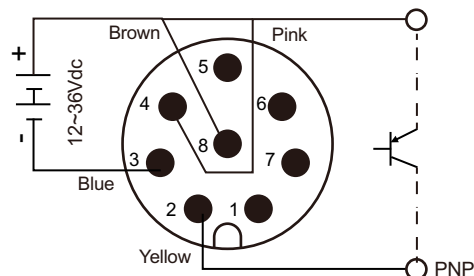

# REQUIREMENTS FOR STRAIGHT PIPE SECTION

The straight pipe must be long enough on the upstream side and downstream side where the flow meter is installed. This can obtain an evenly distributed and stable flow field so as to guarantee the measuring accuracy. When installing the flow meter, please choose optimal distance based on the pipe dimension and field environment. Generally, the longer the section of the straight pipe is, the better. The table below lists the minimum distance based on the times of D(D=pipe diameter).

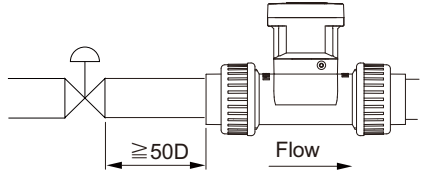
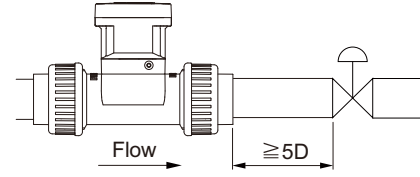
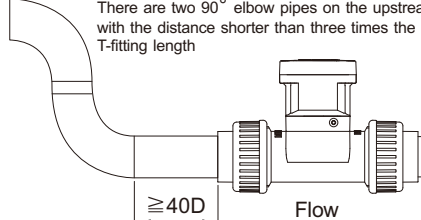
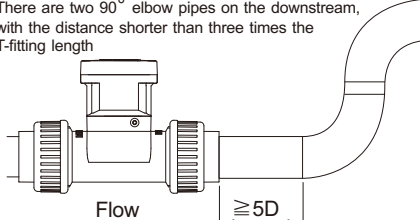
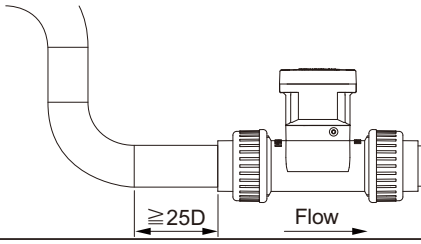
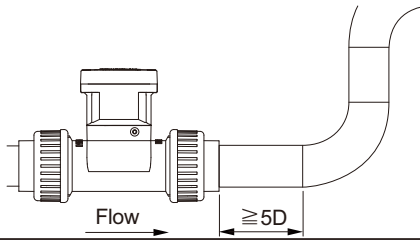
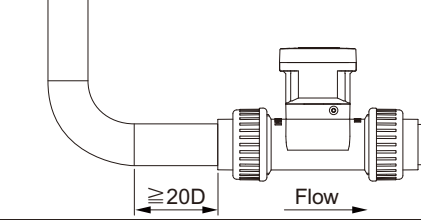
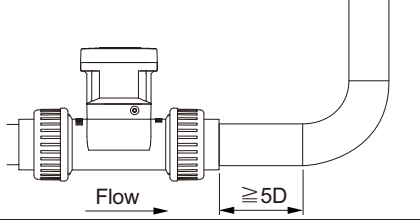
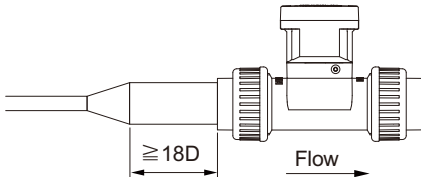
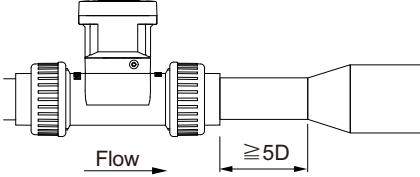
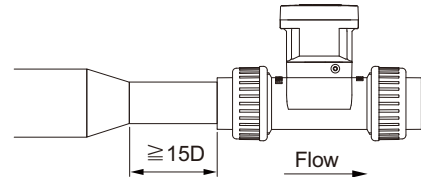
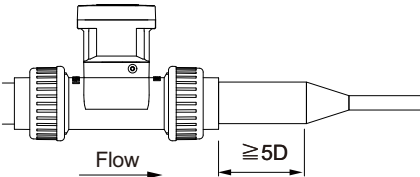
Type	Length of Straight Pipe on the Upstream Side	Length of Straight Pipe on the Downstream Side
Regulating valve		
Keep the two elbow pipes close	<p>There are two 90° elbow pipes on the upstream, with the distance shorter than three times the T-fitting length</p> 	<p>There are two 90° elbow pipes on the downstream, with the distance shorter than three times the T-fitting length</p> 
Dual elbow pipes		
Single elbow pipe		
Diverging pipe		
Converging pipe		

# INSTALLATION REQUIREMENTS

1. The flow meter must be in horizontal or vertical pipe.
2. Ensure the flow meter to keep a full pipe.
3. No air bulb or hole should be generated when getting close to the T-fitting area of the flow meter during the measurement. It will affect the accuracy of the flow measurement.

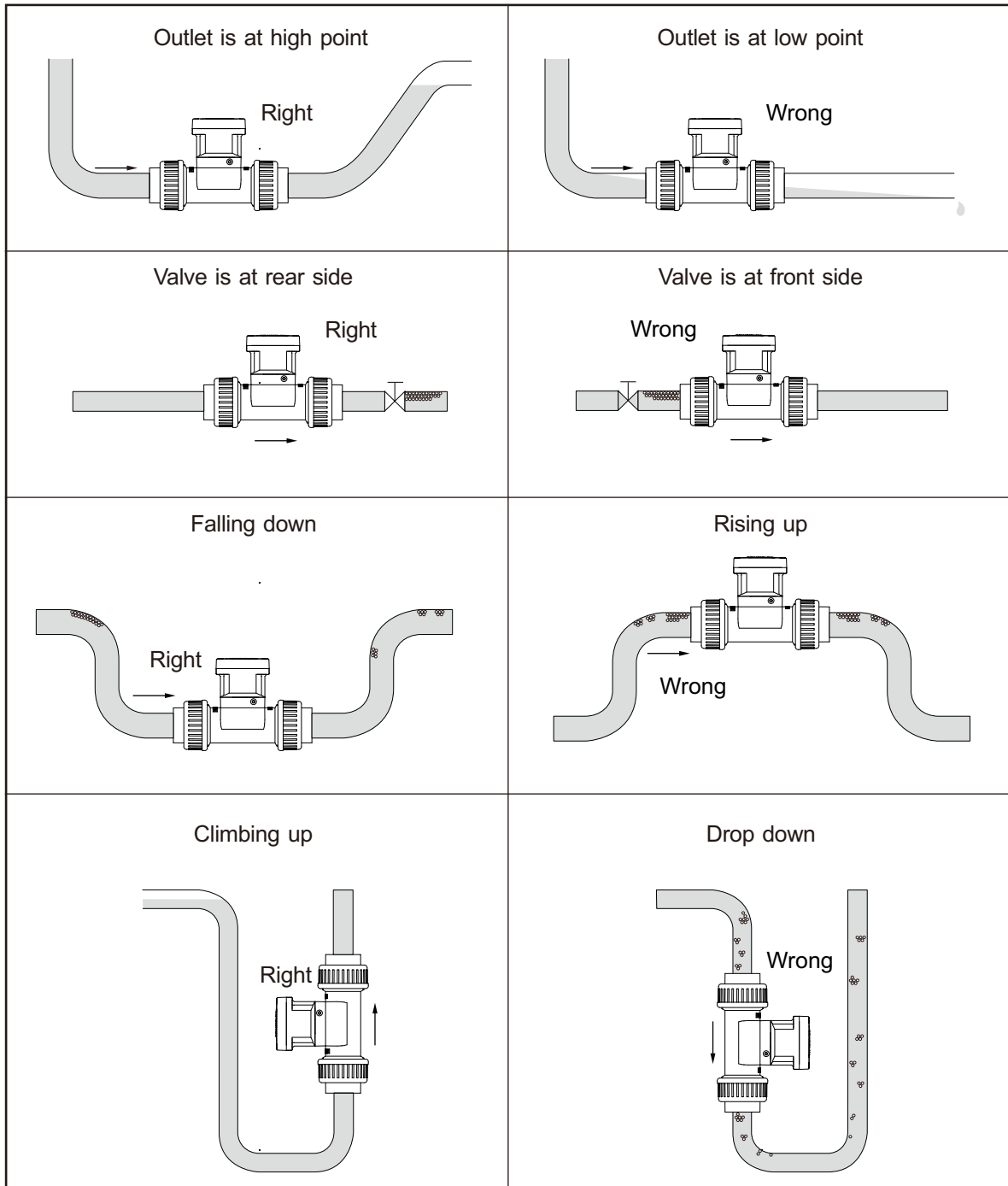

\*Note: When installing the flow meter on the horizontal pipe, the sensor blade must face downward. Appropriate material should be selected, and the specifications on pressure and temperature should be followed. Moreover, appropriate pipe diameter should be chosen based on the flow/velocity/diameter.

# ORDERING INFO

## Paddle Wheel Flowmeter

**EPR1**

<input type="checkbox"/>	<input type="checkbox"/>	<input type="checkbox"/>	<input type="checkbox"/>	<input type="checkbox"/>	<input type="checkbox"/>	<input type="checkbox"/>	<input type="checkbox"/>	<input type="checkbox"/>	<input type="checkbox"/>
--------------------------	--------------------------	--------------------------	--------------------------	--------------------------	--------------------------	--------------------------	--------------------------	--------------------------	--------------------------

Display Model \_\_\_\_\_

- 0: Pulse output model
- 2: Flow transmitter model
- 3: Intelligent All-in-One model

Pipe diameter specification \_\_\_\_\_

- C: DN20
- D: DN25
- E: DN40
- F: DN50

T-fitting specification \_\_\_\_\_

- A: ASTM
  - D: DIN/ISO
  - J: JIS
  - B: PF (Female thread)
  - C: PT (Female thread)
  - E: NPT (Female thread)
  - N: CNS 4053-1
- } It is available for stainless steel only

Outgoing cable type \_\_\_\_\_

- 0: Without connection cable
- A: M12

Certifying institution \_\_\_\_\_

- 0: None

Certification specification \_\_\_\_\_

- 0: None

Power supply specification \_\_\_\_\_

- A: 12~36 Vdc

Output \_\_\_\_\_

- P: Pulse · 4-20mA · RS-485
- D: Pulse (EPR10 pulse output model)

Blade material \_\_\_\_\_

- P: PP
- F: PVDF

Pipe material \_\_\_\_\_

- C: PVC
- 4: SUS304
- 6: SUS316
- 9: SUS316L